

INDOOR UNIT

SERVICE MANUAL

No. TBH014

Wireless type
Models

MS-GD08ND- C1
MS-GD10ND- C1
MS-GD12ND- C1

Outdoor unit service manual
MU-GD·ND Series (TBH016)

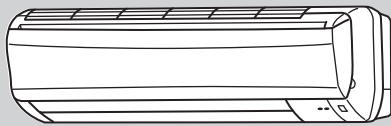

MS-GD08ND- C1
 MS-GD10ND- C1
 MS-GD12ND- C1



CONTENTS

1. TECHNICAL CHANGES	2
2. PART NAMES AND FUNCTIONS	3
3. SPECIFICATION	4
4. OUTLINES AND DIMENSIONS	5
5. WIRING DIAGRAM	6
6. REFRIGERANT SYSTEM DIAGRAM	7
7. SERVICE FUNCTIONS	8
8. TROUBLESHOOTING	10
9. DISASSEMBLY INSTRUCTIONS	19

PARTS CATALOG (TBB014)

NOTE:

• RoHS compliant products have <G> mark on the spec name plate.

Mr. SLIM™

MS-A08ND- [C1] → MS-GD08ND- [C1]

MS-A12ND- [C1] → MS-GD12ND- [C1]

1. Indoor unit has been changed.
 - Front panel has been changed. (Flat → Flat Shining)
2. Terminal block has been changed. 3P (L~, N~, 2~) → 4P (L~, N~, 2~, Earth)

MS-A10ND- [C1] → MS-GD10ND- [C1]

1. Indoor unit has been changed.
 - Front panel has been changed. (Flat → Flat Shining)

2

PART NAMES AND FUNCTIONS

INDOOR UNIT

MS-GD08ND- C1

MS-GD10ND- C1

MS-GD12ND- C1

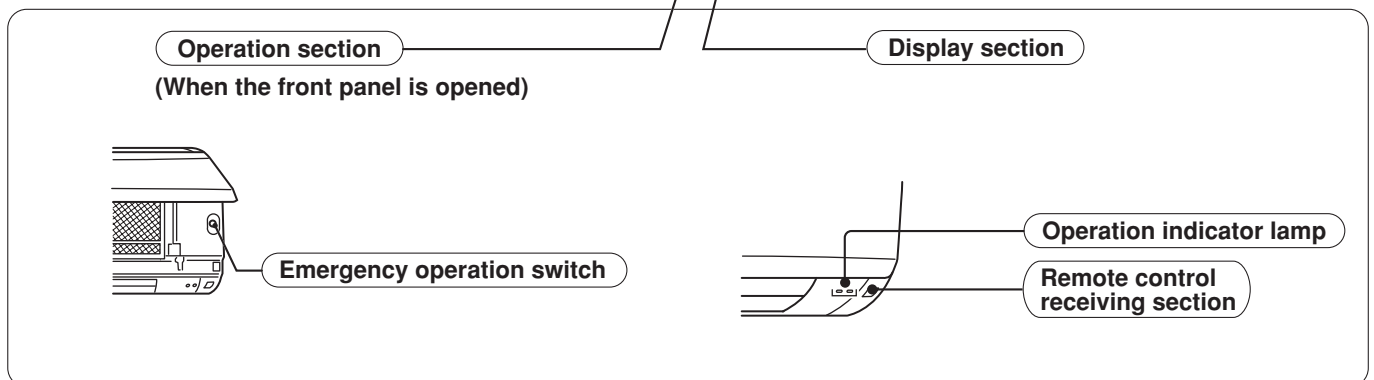
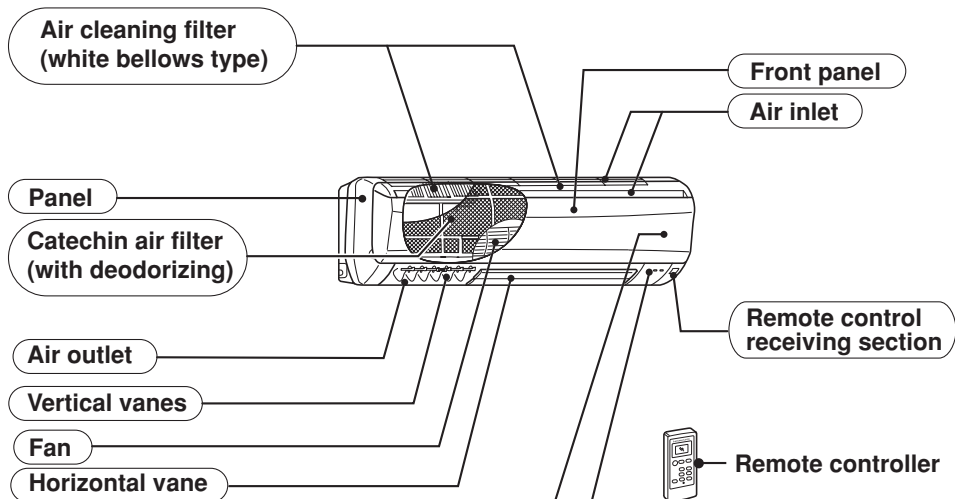

ACCESSORIES

		MS-GD08ND- <small>C1</small> MS-GD10ND- <small>C1</small> MS-GD12ND- <small>C1</small>
①	Installation plate	1
②	Installation plate fixing screw 4 x 25 mm	5
③	Remote controller holder	1
④	Fixing screw for ③ 3.5 x 16 mm (Black)	2
⑤	Battery (AAA) for remote controller	2
⑥	Wireless remote controller	1
⑦	Felt tape (Used for left or left-rear piping)	1
⑧	Air cleaning filter	2

REMOTE CONTROLLER

MS-GD08ND- C1

MS-GD10ND- C1

MS-GD12ND- C1

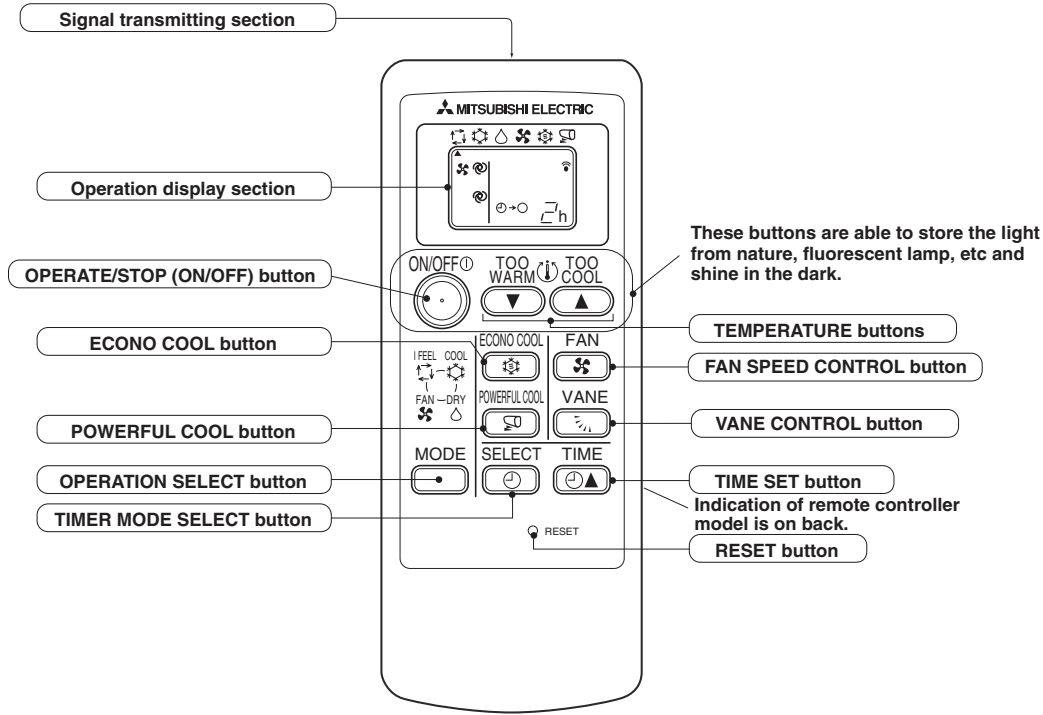

3

SPECIFICATION

Indoor model			MS-GD08ND- C1	MS-GD10ND- C1	MS-GD12ND- C1
Function			Cooling		
Power supply			Single phase 220-230V, 60Hz		
Capacity	Air flow (High/Med/Low)	m³/h	588/456/372	630/498/336	666/498/336
Electrical data	Power outlet	A	10		
	Running current	A	0.19		
	Power input	W	40		
	Auxiliary heater	A (kW)	—		
	Power factor	%	96-92		
	Fan motor current	A	0.19		
Fan motor	Model		RC4N19-BA		
	Winding resistance (at 20°C)	Ω	WHT-BLK 312 BLK-RED 255		
Dimensions W×H×D		mm	815×278×244		
Weight		kg	9	10	
Special remarks	Air direction		5		
	Sound level (High/Med/Low)	dB	39/32/26	39/32/26	42/36/29
	Fan speed (High/Med/Low)	rpm	1030/800/650	960/800/650	1000/800/650
	Fan speed regulator		3		
	Thermistor RT11 (at 25°C)	kΩ	10		
	Thermistor RT12 (at 25°C)	kΩ	10		
Remote controller model			MP2B		

NOTE: Test conditions are based on CNS 14464

Cooling : Indoor Dry-bulb temperature 27°C Wet-bulb temperature 19°C

Outdoor Dry-bulb temperature 35°C Wet-bulb temperature 24°C

Refrigerant piping length (one way) 7.5 m

5

WIRING DIAGRAM

MS-GD08ND- C1

MS-GD12ND- C1

INDOOR UNIT

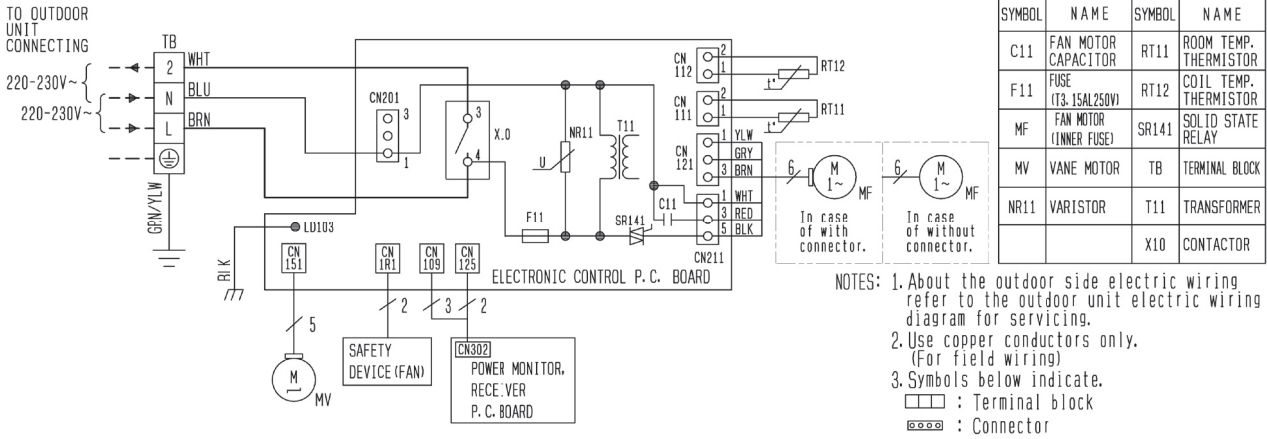

MS-GD10ND- C1

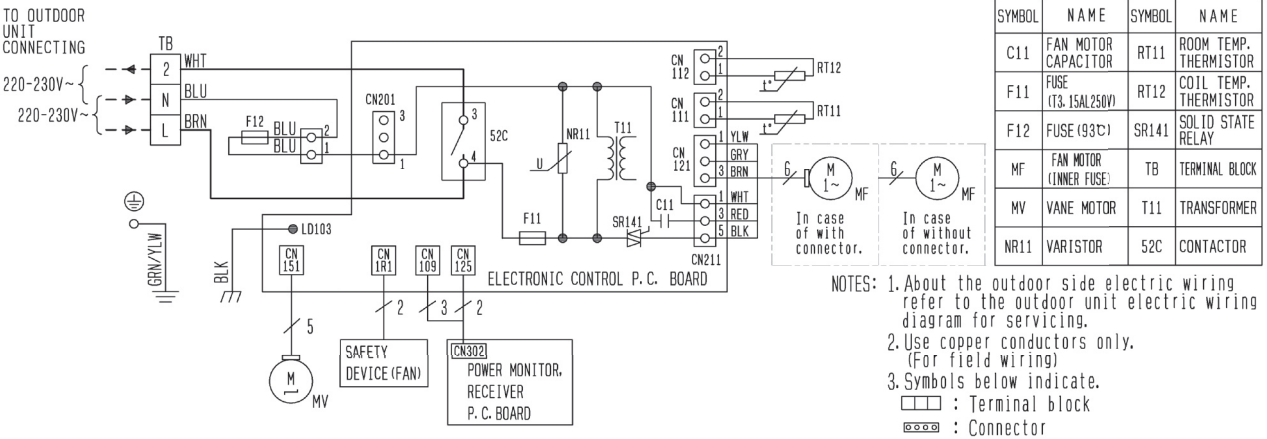

MS-GD08ND- C1
MS-GD10ND- C1

INDOOR UNIT

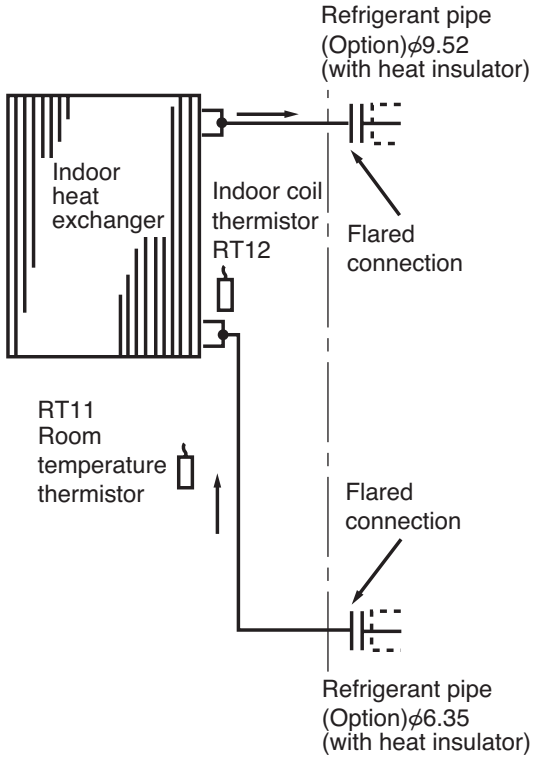

MS-GD12ND- C1

INDOOR UNIT

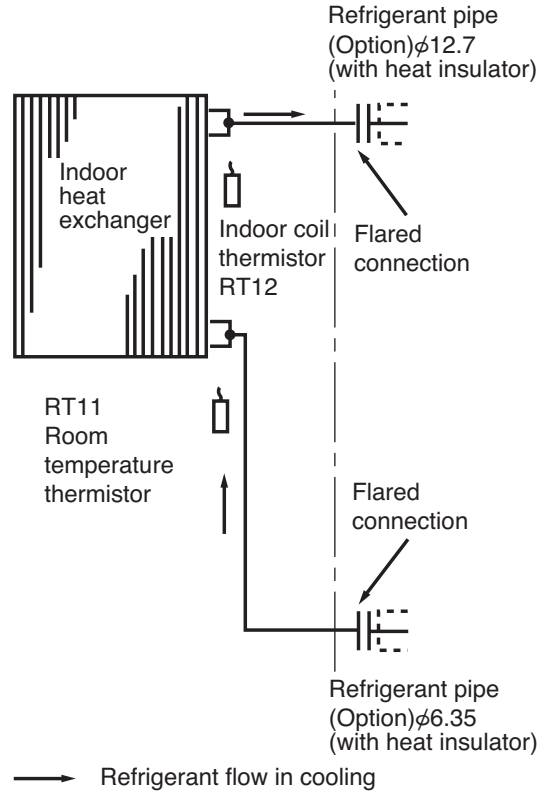

MS-GD08ND- C1

MS-GD10ND- C1

MS-GD12ND- C1

7-1. TIMER SHORT MODE

For service, set time can be shortened by short circuit of JPG and JPS the electronic control P.C. board.

The time will be shortened as follows. (Refer to 8-6.)

Set time : 1-minute → 1-second

Set time : 3-minute → 3-second

It takes 3 minutes for the compressor to start operation. However, the starting time is shortened by short circuit of JPG and JPS.

7-2. P.C. BOARD MODIFICATION FOR INDIVIDUAL OPERATION

A maximum of 4 indoor units with wireless remote controllers can be used in a room.

In this case, to operate each indoor unit individually by each remote controller, P.C. boards of remote controller must be modified according to the number of the indoor unit.

How to modify the remote controller P.C. board

Remove batteries before modification.

The board has a print as shown below :

Remote controller model : MP2B

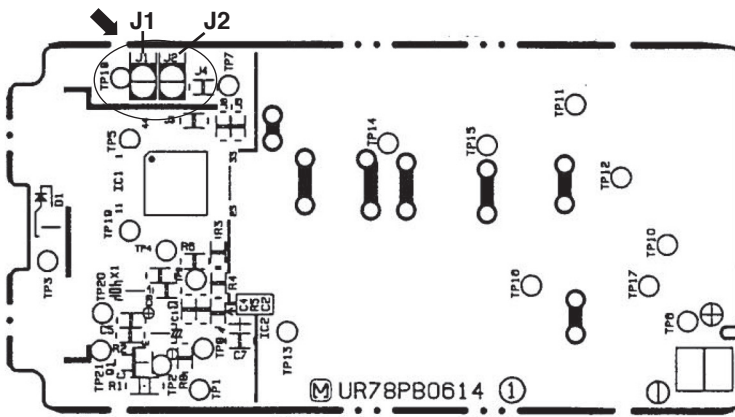

NOTE : For remodelling, take out the batteries and push the OPERATE/STOP(ON/OFF)button twice or 3 times at first. After finish remodelling, put back the batteries then press the RESET button.

The P.C. board has the print "J1" and "J2". Solder "J1" and "J2" according to the number of indoor unit as shown in Table 1. After modification, press the RESET button.

Table 1

	1 unit operation	2 units operation	3 units operation	4 units operation
No. 1 unit	No modification	Same as at left	Same as at left	Same as at left
No. 2 unit	—	Solder J1	Same as at left	Same as at left
No. 3 unit	—	—	Solder J2	Same as at left
No. 4 unit	—	—	—	Solder both J1 and J2

How to set the remote controller exclusively for particular indoor unit

After you turn the breaker ON, the first remote controller that sends the signal to the indoor unit will be regarded as the remote controller for the indoor unit.

The indoor unit will only accept the signal from the remote controller that has been assigned to the indoor unit once they are set.

The setting will be cancelled if the breaker has turned off, or the power supply has shut down.

Please conduct the above setting once again after the power has restored.

7-3. AUTO RESTART FUNCTION

When the indoor unit is controlled with the remote controller, the operation mode, set temperature, and the fan speed are memorized by the indoor electronic control P.C.board. The "AUTO RESTART FUNCTION" sets to work the moment power has restored after power failure. Then, the unit will restart automatically. However if the unit is operated in "I FEEL CONTROL" mode before power failure, the operation is not memorized. In "I FEEL CONTROL" mode, the operation is decided by the initial room temperature.

Operation

- ① If the main power has been cut, the operation settings remain.
- ② After the power is restored, the unit automatically resumes the same operation as the memory has recorded.
However, it takes the compressor at least 3 minutes to get started.

How to release "AUTO RESTART FUNCTION"

- ① Turn off the main power for the unit.
- ② Pull out the indoor electronic control P.C. board and the power monitor, receiver P.C. board. (Refer to 9-1.)
- ③ Solder the Jumper wire to the JR07 on the indoor electronic control P.C.board. (Refer to 8-6.)

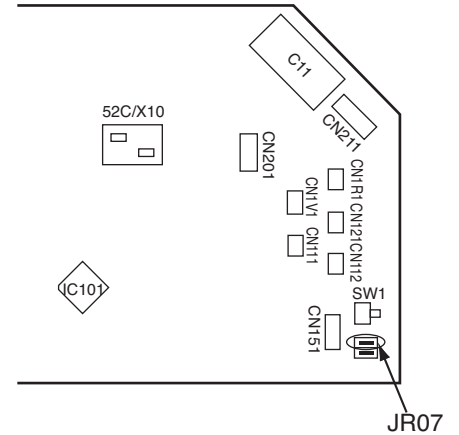

NOTE:

- The operation settings are memorized when 10 seconds have passed after the indoor unit was operated with the remote controller.
- If the main power is turned off or a power failure occurs while AUTO START/STOP timer is active, the timer setting is cancelled.
- If the unit has been off with the remote controller before power failure, the auto restart function does not work as the power button of the remote controller is off.
- To prevent breaker off due to the rush of starting current, systematize other home appliances not to turn on at the same time.
- When some air conditioners are connected to the same supply system, if they are operated before power failure, the starting current of all the compressors may flow simultaneously at restart. Therefore, the special counter-measures are required to prevent the main voltage-drop or the rush of the starting current by adding to the system that allows the units to start one by one.

MS-GD08ND- C1

MS-GD10ND- C1

MS-GD12ND- C1

8-1. Cautions on troubleshooting**1. Before troubleshooting, check the following:**

- 1) Check the power supply voltage.
- 2) Check the indoor/outdoor connecting wire for mis-wiring.

2. Take care the following during servicing.

- 1) Before servicing the air conditioner, be sure to turn off the main unit first with the remote controller, and then after confirming the horizontal vane is closed, turn off the breaker and / or disconnect the power plug.
- 2) Be sure to turn OFF the power supply before removing the front panel, the cabinet, the top panel and the electronic control P.C. board.
- 3) When removing the electronic control P.C. board, hold the edge of the board with care NOT to apply stress on the components.
- 4) When connecting or disconnecting the connectors, hold the housing of the connector. DO NOT pull the lead wires.

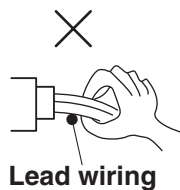

Lead wiring

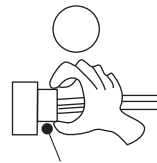

Housing point

3. Troubleshooting procedure

- 1) First, check if the OPERATION INDICATOR lamp on the indoor unit is flashing on and off to indicate an abnormality. To make sure, check how many times the abnormality indication is flashing on and off before starting service work.
- 2) Before servicing that the connector and terminal are connected properly.
- 3) If the electronic control P.C. board is supposed to be defective, check the copper foil pattern for disconnection and the components for bursting and discolouration.
- 4) When troubleshooting, refer to 8-2. and 8-3.

4. How to replace batteries

Weak batteries may cause the remote controller malfunction.

In this case, replace the batteries to operate the remote controller normally.

- ① Remove the back lid and insert batteries. Then reattach the back lid.

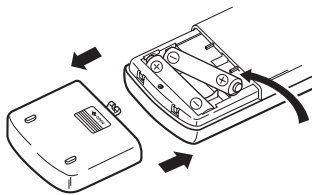

Insert the negative pole of the batteries first. Check if the polarity of the batteries are correct.

- ② Press the RESET button with tip end of ball point pen or the like, and then use the remote controller.

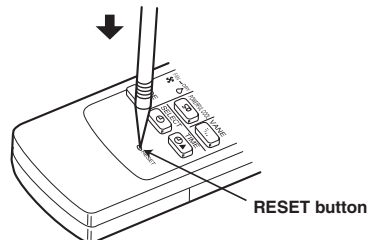

NOTE : 1. If the RESET button is not pressed, the remote controller may not operate correctly.

2. This remote controller has a circuit to automatically reset the microcomputer when batteries are replaced.

This function is equipped to prevent the microcomputer from malfunctioning due to the voltage drop caused by the battery replacement.

5. How to install the horizontal vanes

If horizontal vanes are not installed correctly, both of the operation indicator lamps will flash. In this case, install the horizontal vanes correctly by following the procedures ① to ⑥.

NOTE: Before installation of the horizontal vanes, disconnect the power supply plug and/ or turn off the breaker.

Upper vane

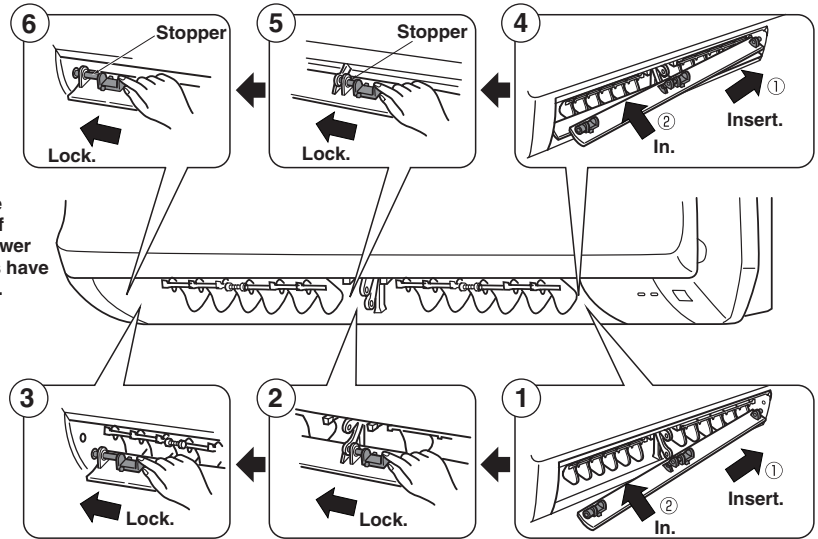
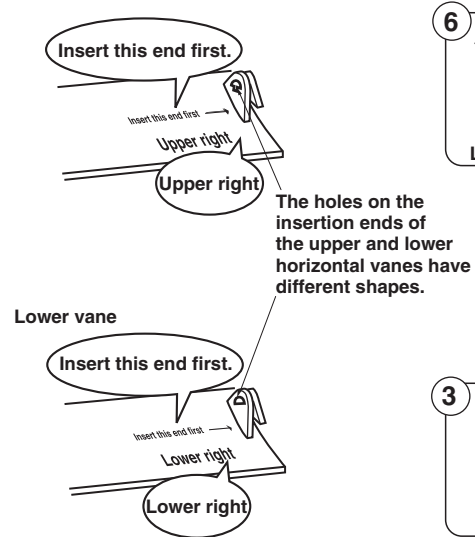

In procedure ②, ③, ⑤, and ⑥, lock the stoppers until they click into place.

8-2. Instruction of troubleshooting

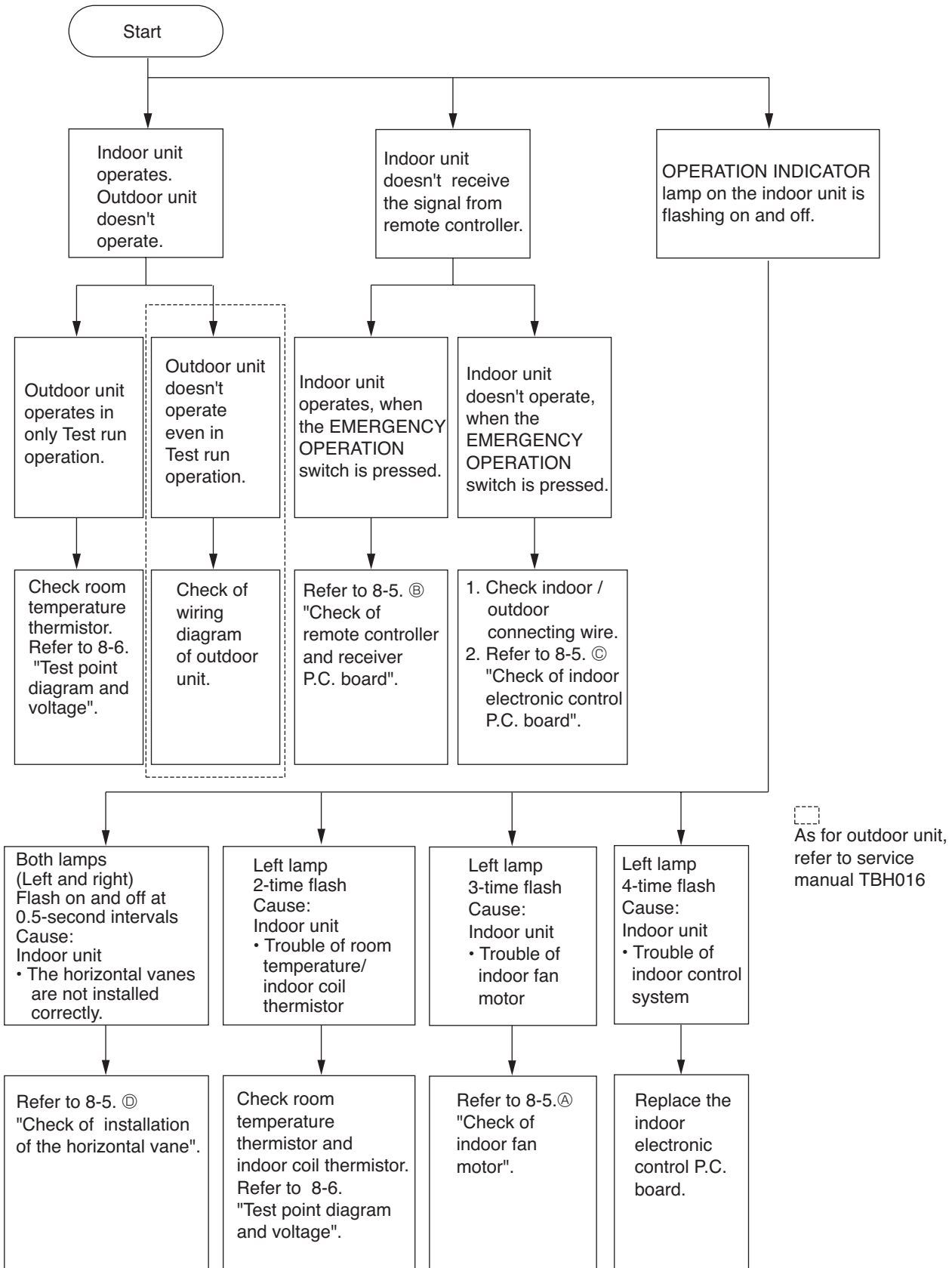

8-3. Troubleshooting check table

- The following indication applies regardless of shape of the indicator.

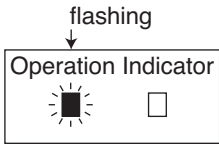

- Flashing of the OPERATION INDICATOR lamp (on the left) indicates possible abnormalities.
- The OPERATION INDICATOR lamp (on the left) is lighting during normal operation.

Before taking measures, make sure that the symptom reappears for accurate troubleshooting.
Self check table

No.	Abnormal point	Indication	Symptom	Detection method	Check point
1	Attachment of the horizontal vane	Both lamps flash at the same time. 0.5-second ON ●○○●○○●○○ 0.5-second OFF	Indoor unit and outdoor unit do not operate.	When the electricity is not conducted to the safety device (FAN) of the horizontal vane.	• Refer to 8-5. ⑥ "Check of installation of the horizontal vane".
2	Indoor coil thermistor Room temperature thermistor	Left lamp flashes. 2-time flash ●○○○○○○○○●○○ 2.5-second OFF	Outdoor unit does not operate.	Detect Indoor coil/room temperature thermistor short or open circuit every 8 seconds during operation.	• Refer to the characteristics of indoor coil thermistor and room temperature thermistor shown in 8-6.
3	Indoor fan motor.	Left lamp flashes. 3-time flash ●○○●○○○○○○○○●○○●○○○○ 2.5-second OFF	Indoor fan motor repeats 12 seconds ON and 3 minutes OFF. When the indoor fan motor breaks, the fan keeps stopping.	When rotational frequency feedback signal is not emitting during 12-second indoor fan operation.	• Refer to 8-5. ⑦ "Check of indoor fan motor".
4	Indoor control system	Left lamp flashes. 4-time flash ●○○●○○○○○○○○●○○●○○○○ 2.5-second OFF	Outdoor unit does not operate.	When it cannot properly read data in the nonvolatile memory of the indoor electronic control P.C. board.	• Replace the indoor electronic control P.C. board.

NOTE : When the indoor unit has started operation and the above detection method has detected an abnormality (the first detection after the power ON), the indoor electronic control P.C. board turns OFF the indoor fan motor with the OPERATION INDICATOR lamp flashing.

8-4. Trouble criterion of main parts

MS-GD08ND- C1

MS-GD10ND- C1

MS-GD12ND- C1

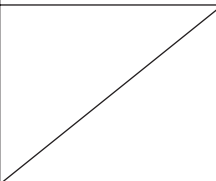
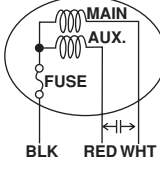
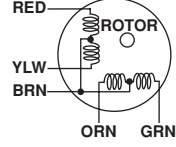
Part name	Check method and criterion	Figure								
Room temperature thermistor (RT11)	Measure the resistance with a tester. (Part temperature 10°C ~ 30°C) <table border="1" style="margin: 10px auto; width: 80%;"> <thead> <tr> <th style="width: 50%;">Normal</th> <th style="width: 50%;">Abnormal</th> </tr> </thead> <tbody> <tr> <td style="text-align: center;">8kΩ ~ 20kΩ</td> <td style="text-align: center;">Open or short-circuit</td> </tr> </tbody> </table>	Normal	Abnormal	8kΩ ~ 20kΩ	Open or short-circuit					
Normal		Abnormal								
8kΩ ~ 20kΩ	Open or short-circuit									
Indoor coil thermistor (RT12)										
Indoor fan motor (MF)	Measure the resistance between the terminals with a tester. (Coil wiring temperature 10°C ~ 30°C) <table border="1" style="margin: 10px auto; width: 80%;"> <thead> <tr> <th style="width: 20%;">Color of lead wire</th> <th style="width: 30%;">Normal</th> <th style="width: 50%;">Abnormal</th> </tr> </thead> <tbody> <tr> <td>WHT-BLK</td> <td style="text-align: center;">299~324Ω</td> <td rowspan="2" style="text-align: center;">Open or short-circuit</td> </tr> <tr> <td>BLK-RED</td> <td style="text-align: center;">244~265Ω</td> </tr> </tbody> </table>	Color of lead wire	Normal	Abnormal	WHT-BLK	299~324Ω	Open or short-circuit	BLK-RED	244~265Ω	
Color of lead wire	Normal	Abnormal								
WHT-BLK	299~324Ω	Open or short-circuit								
BLK-RED	244~265Ω									
INNER FUSE 145± 2°C CUT OFF	Measure the voltage Power ON. <table border="1" style="margin: 10px auto; width: 80%;"> <thead> <tr> <th style="width: 20%;">Color of lead wire</th> <th style="width: 30%;">Normal</th> <th style="width: 50%;">Abnormal</th> </tr> </thead> <tbody> <tr> <td>BRN-YLW</td> <td style="text-align: center;">4.5 ~ 5.5V</td> <td rowspan="2" style="text-align: center;">Remain 0V or 5V</td> </tr> <tr> <td>YLW-GRY</td> <td style="text-align: center;">(When fan revolved one time) 0V→5V→0V (Approx.)</td> </tr> </tbody> </table>	Color of lead wire	Normal	Abnormal	BRN-YLW	4.5 ~ 5.5V	Remain 0V or 5V	YLW-GRY	(When fan revolved one time) 0V→5V→0V (Approx.)	
Color of lead wire	Normal	Abnormal								
BRN-YLW	4.5 ~ 5.5V	Remain 0V or 5V								
YLW-GRY	(When fan revolved one time) 0V→5V→0V (Approx.)									
Vane motor (MV)	Measure the resistance between the terminals with a tester. (Part temperature 10°C ~ 30°C) <table border="1" style="margin: 10px auto; width: 80%;"> <thead> <tr> <th style="width: 50%;">Normal</th> <th style="width: 50%;">Abnormal</th> </tr> </thead> <tbody> <tr> <td style="text-align: center;">240 ~ 260Ω</td> <td style="text-align: center;">Open or short-circuit</td> </tr> </tbody> </table>	Normal	Abnormal	240 ~ 260Ω	Open or short-circuit					
Normal	Abnormal									
240 ~ 260Ω	Open or short-circuit									

8-5. Troubleshooting flow
When left OPERATION INDICATOR lamp flashes 3-time.
Indoor fan motor doesn't operate.

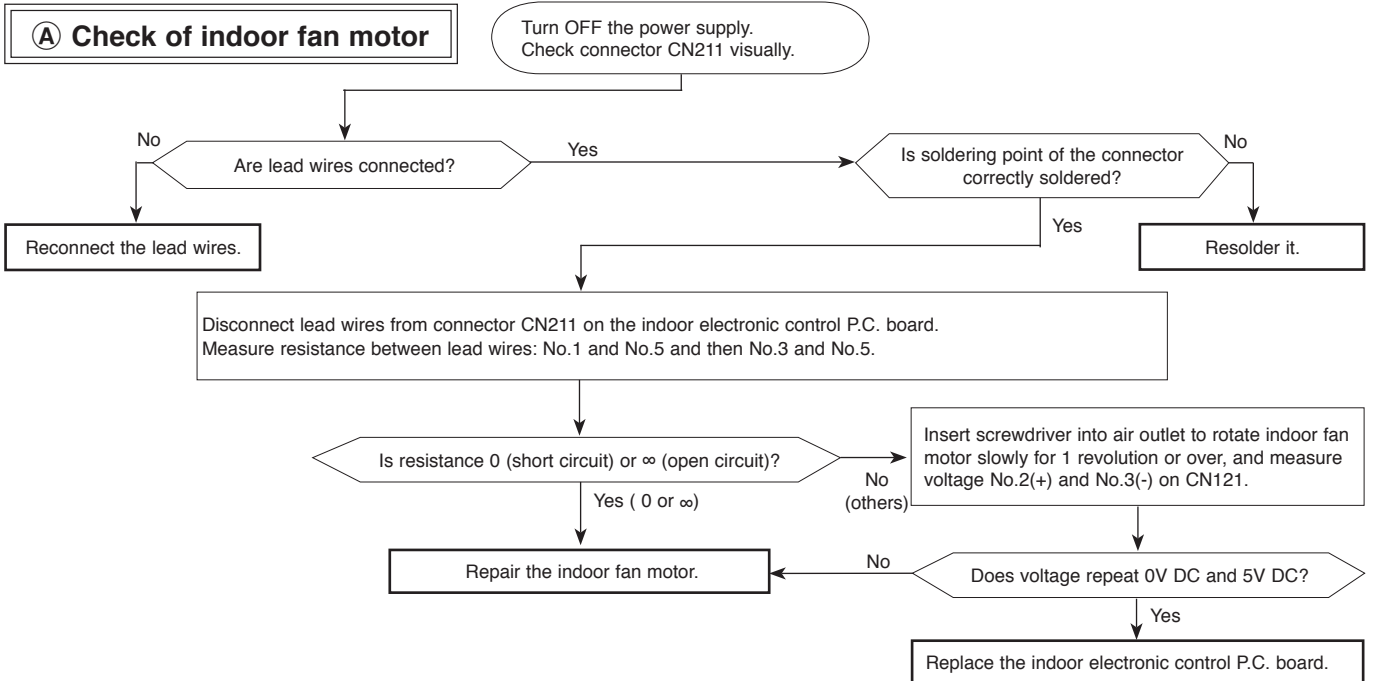

Indoor unit operates by pressing the EMERGENCY OPERATION switch, but doesn't operate with the remote controller.

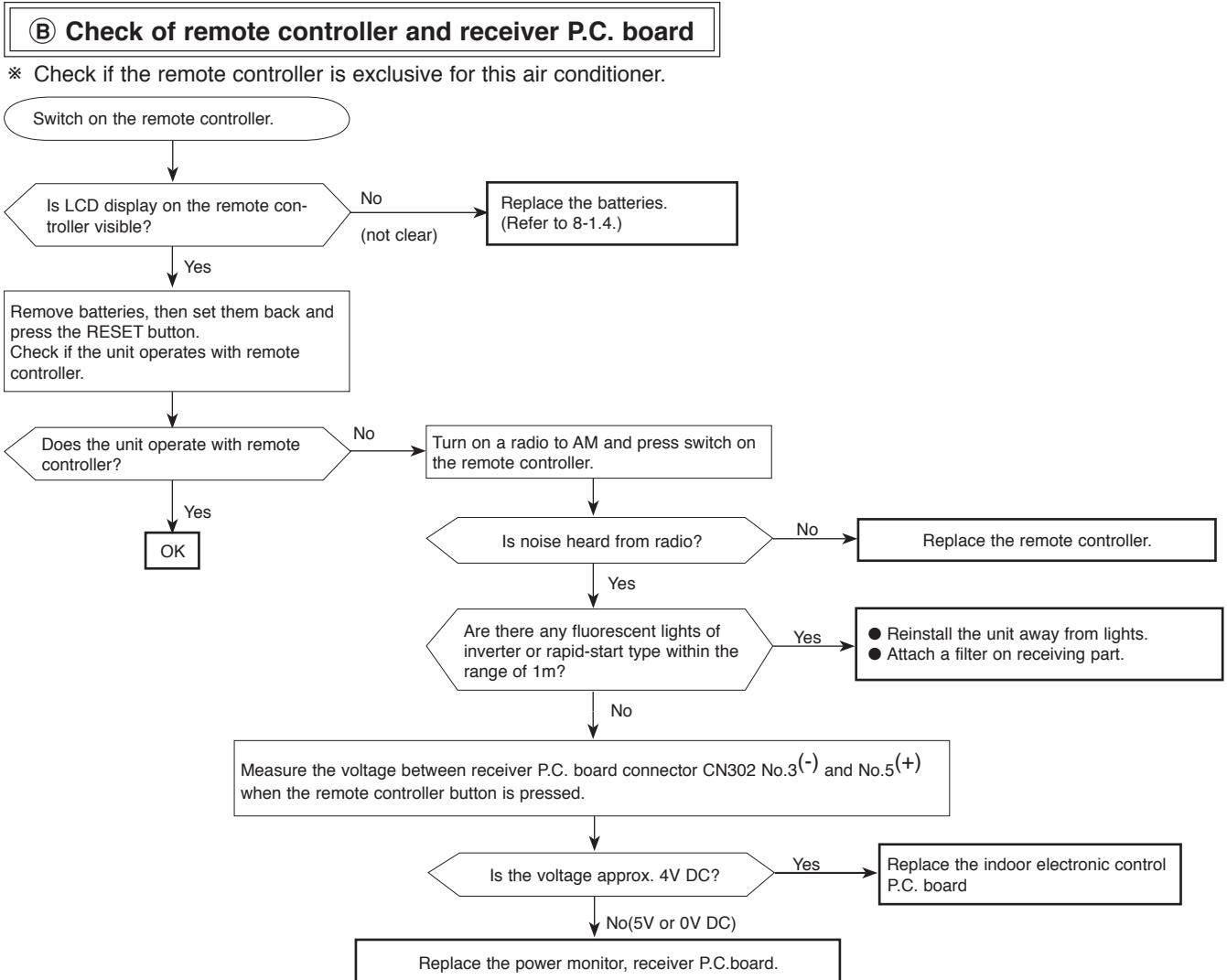

The unit doesn't operate with the remote controller.
 Also, the OPERATION INDICATOR lamp doesn't light up by pressing the EMERGENCY OPERATION switch.

© Check of indoor electronic control P.C. board

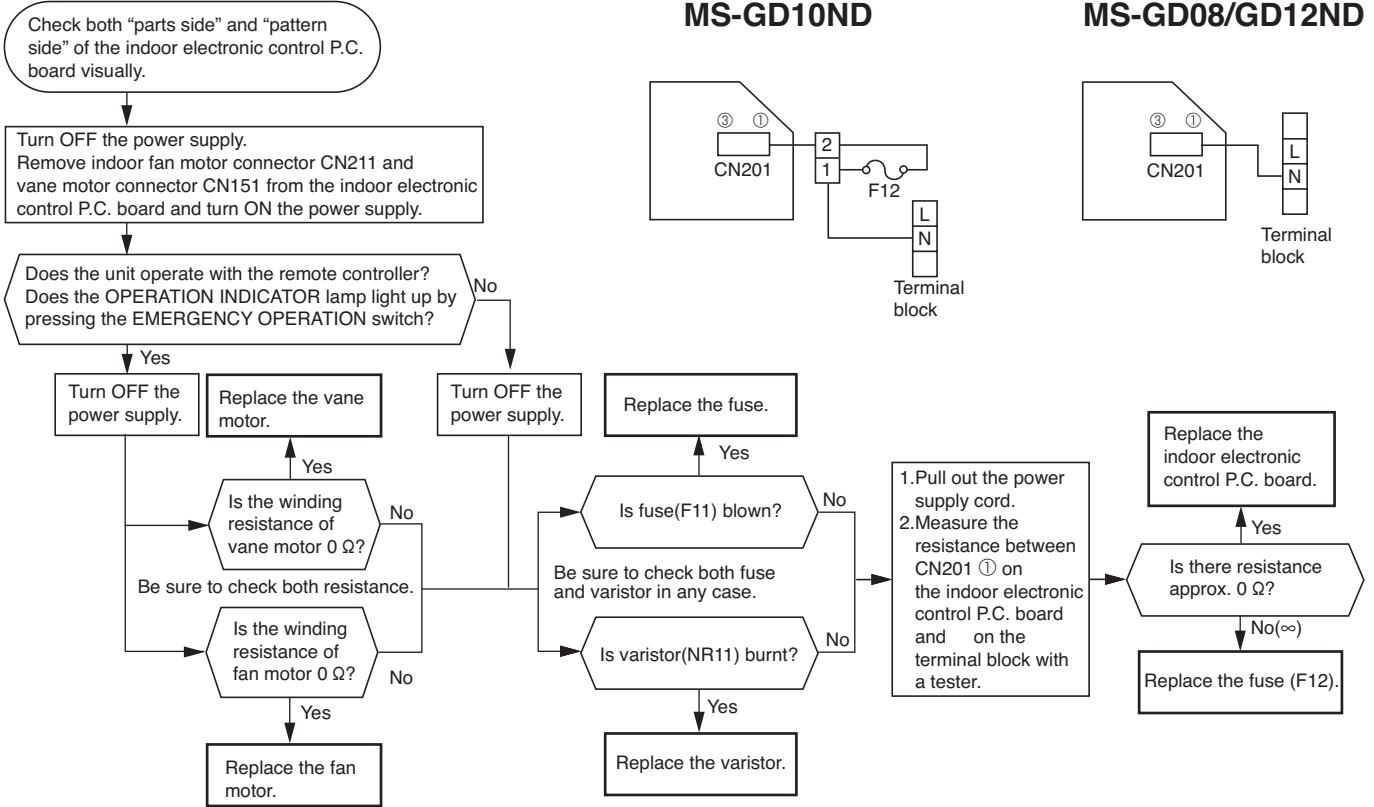

When both OPERATION INDICATOR lamps flash ON and OFF every 0.5-second.
Indoor unit and outdoor unit don't operate.

D Check of installation of the horizontal vane

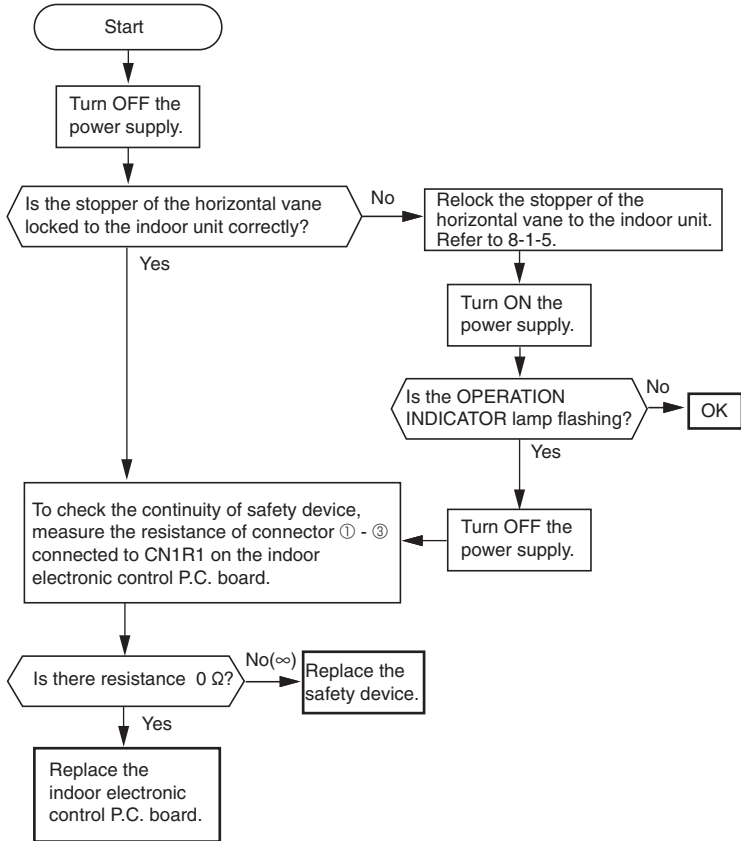

8-6. Test point diagram and voltage

MS-GD08ND- C1

MS-GD10ND- C1

MS-GD12ND- C1

Indoor electronic control P.C. board

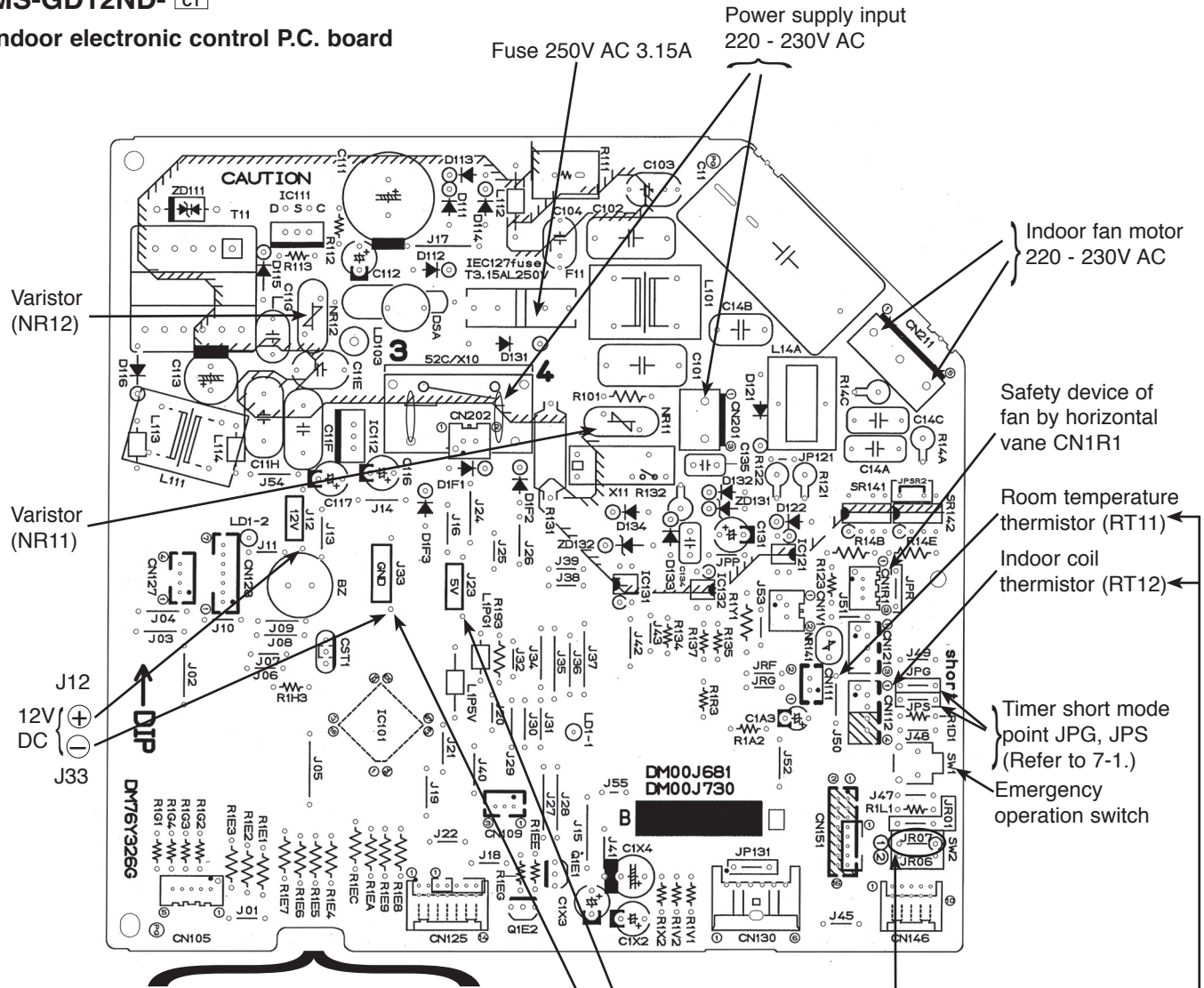

Power monitor, receiver P.C. board

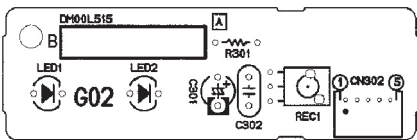

CN302

Indoor coil thermistor (RT12)
Room temperature thermistor (RT11)

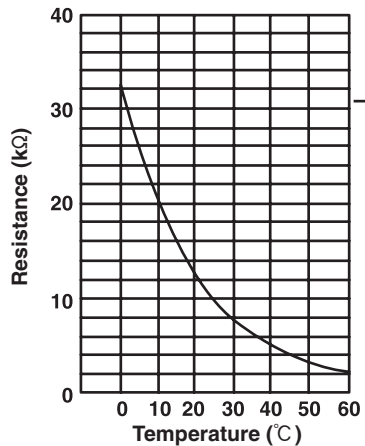

<"Terminal with locking mechanism" Detaching points>

The terminal which has the locking mechanism can be detached as shown below.
There are two types (Refer to (1) and (2)) of the terminal with locking mechanism.
The terminal without locking mechanism can be detached by pulling it out.
Check the shape of the terminal before detaching.

(1) Slide the sleeve and check if there is a locking lever or not.

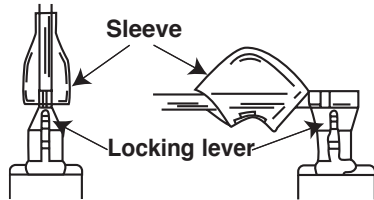

- ① Slide the sleeve.
- ② Pull the terminal while pushing the locking lever.

(2) The terminal with this connector has the locking mechanism.



- ① Hold the sleeve, and pull out the terminal slowly.

9.1 MS-GD08ND-  MS-GD10ND-  MS-GD12ND- 

INDOOR UNIT

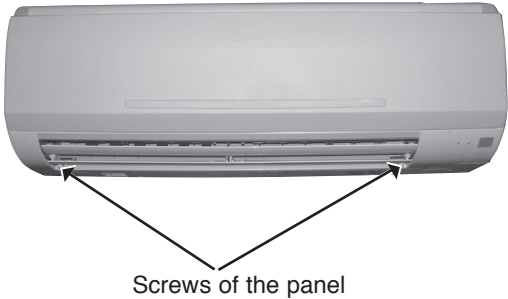
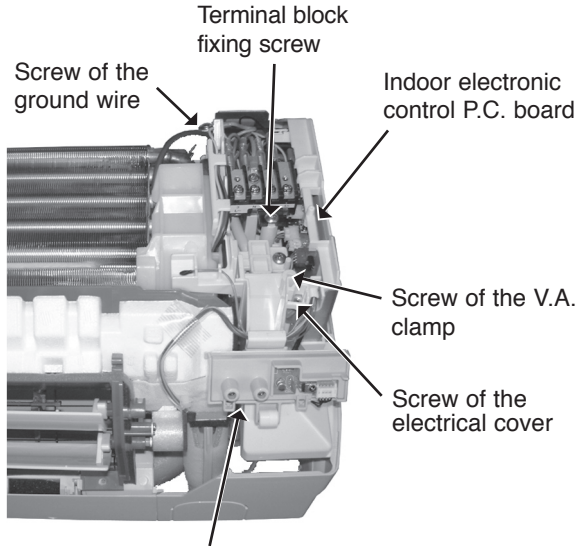
OPERATING PROCEDURE	PHOTOS
<p>1. Removing the panel</p> <ol style="list-style-type: none"> (1) Remove the screw caps of the panel. Remove the screws. (2) Pull the panel down to your side slightly and unhook the catches at the top. 	<p>Photo 1</p> 
<p>2. Removing the electronic control P.C. board and the power monitor, receiver P.C. board</p> <p>NOTE : In case of removing only indoor electronic control P.C. board work (3) is not necessary.</p> <ol style="list-style-type: none"> (1) Remove the panel. (Refer to 1.) (2) Remove the power monitor, receiver P.C. board holder from the bottom of electrical box. (3) Open the power monitor, receiver P.C. board holder and remove the power monitor, receiver P.C. board. (4) Remove the screw of the electrical cover and the electrical cover. (5) Remove the screw of the V.A. clamp and the V.A. clamp. (6) Remove the screw of the cord clamp and the cord clamp. (7) Remove the screw of the terminal block. (8) Remove the screw of the ground wire. (9) Pull out indoor electronic control P.C. board slightly. (10) Disconnect all (except CN125, CN109) the connectors on the electronic control P.C. board. (11) Remove the electronic control P.C. board. (12) Disconnect the connector of power monitor, receiver P.C. board (CN 125, CN109) on the electronic control P.C. board. 	<p>Photo 2</p> 

OPERATING PROCEDURE

3. Removing the electrical box

- (1) Remove the panel. (Refer to 1.)
- (2) Remove the electrical cover. (Refer to 2.)
- (3) Remove the V.A. clamp. (Refer to 2.)
- (4) Remove the cord clamp. (Refer to 2.)
- (5) Remove the terminal block. (Refer to 2.)
- (6) Remove the screw of ground wire. (Refer to 2.)
- (7) Disconnect the connector of the indoor coil thermistor (CN112), the fan motor connector (CN211 and CN121) and the vane motor connector (CN151) on the electronic control P.C. board.
- (8) Remove the fan motor lead wire and indoor coil thermistor from the electrical box.
- (9) Remove the lead wire of vane motor from the bottom of electrical box.
- (10) Remove the screw fixing the electrical box, remove the electrical box.

4. Removing the nozzle assembly and the vane motor

- (1) Remove the panel. (Refer to 1.)
- (2) Remove the electrical box. (Refer to 3.)
- (3) Pull out the drain hose from the nozzle assembly, remove the nozzle assembly.
- (4) Remove the screws of the vane motor, disconnect the vane motor connector.
- (5) Remove the vane motor.

5. Removing the indoor fan motor and the line flow fan

- (1) Remove the panel. (Refer to 1.)
- (2) Remove the electrical box. (Refer to 3.)
- (3) Pull out the drain hose from the nozzle assembly, and remove the nozzle assembly. (Refer to 4.)
- (4) Remove the screw of the lead cover and lead cover.
- (5) Release the hooks to open the motor band slightly.
- (6) Loosen the hexagon socket set screw from the line flow fan.
- (7) Remove the screws fixing the motor bed, and remove the fan motor with motor band and the motor bed.
- (8) Remove the screws fixing the left side of the heat exchanger.
- (9) Lift the left side of the heat exchanger.
- (10) Remove the line flow fan.

Photo 6

Hexagon socket set screw

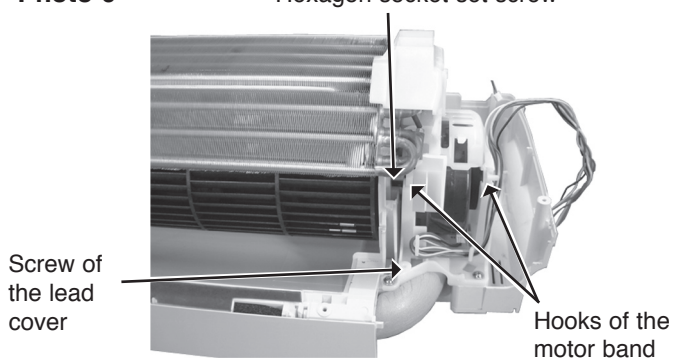

PHOTOS

Photo 3

Indoor coil thermistor connector
Vane motor connector
Screw of the electrical box

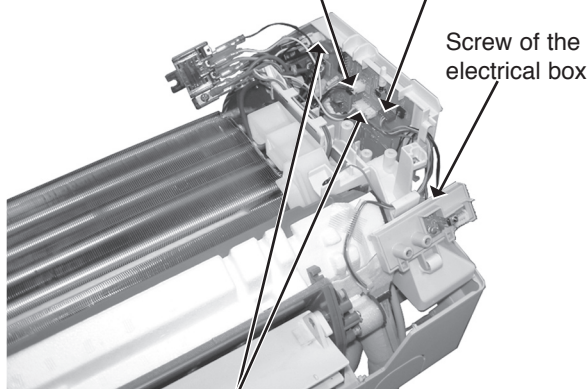

Fan motor connectors

Photo 4

Screws of the vane motor

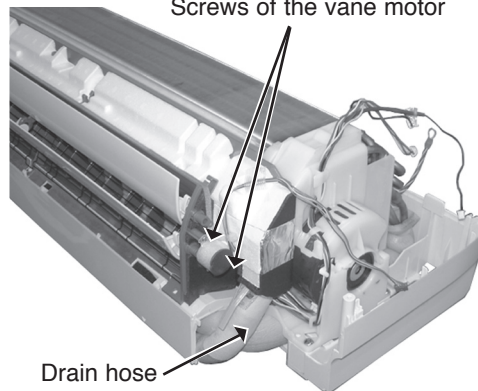

Drain hose

Photo 5

Screws of the left side of the heat exchanger

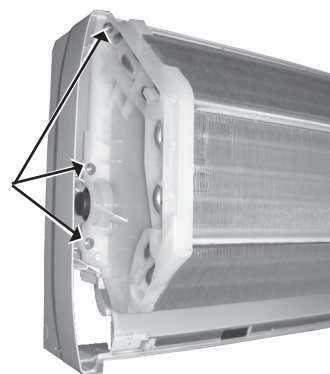
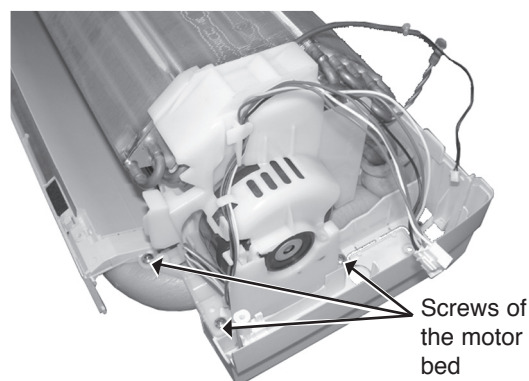

Photo 7



Screws of the motor bed

Mr. SLIM™

 **mitsubishi ELECTRIC CORPORATION**

HEAD OFFICE: TOKYO BLDG., 2-7-3, MARUNOUCHI, CHIYODA-KU, TOKYO 100-8310, JAPAN

mitsubishi ELECTRIC CONSUMER PRODUCTS (THAILAND) CO., LTD.
AMATA NAKORN INDUSTRIAL ESTATE
700/406 MOO 7, TAMBON DON HUA ROH,
AMPHUR MUANG, CHONBURI 20000 THAILAND
Made in Thailand

New publication, effective Feb. 2008
Specifications subject to change without notice.